

2019 PHS PHILADELPHIA FLOWER SHOW

“Flower Power”

March 2 – 10, 2019

ARRANGEMENT CLASSES STAGING INFORMATION

CONTENTS

OPEN PLATFORM— (100-P, 103-P, 108-P, 114-P)	2
MEDIUM NICHE— (101-M, 104-M, 109-M, 115-M)	4
LINING MEDIUM NICHE WITH MAT BOARD	5
SMALL NICHE— (102-S, 105-S, 110-S, 116-S).....	6
LINING SMALL NICHE WITH MAT BOARD	7
GALLERIA (125-G, 126-G, 127-G, 128-G)	8
BACKED PEDESTAL— (129-BP, 130-BP, 131-BP, 132 BP).....	9
MINIATURE ARRANGEMENTS (119, 120, 121, 122, 123, 124).....	12
MINIATURE ARRANGEMENT GUIDELINES	13
MINIATURE BOX CONSTRUCTION TIPS	14
PHOTOGRAPHS OF NICHE LIGHTING	15
HANGING FRAMES.....	16

OPEN PLATFORM

100-P, 103-P, 108-P, 114-P

This class was previously called "Pedestals." Please be sure to read the *General Rules and Information* (page 10) and *Staging Information – Open Platforms* (page 11) in the 2019 Exhibitor's Guide.

Staged on a platform 8' wide by 4' deep, 4" high. No part of the entry may extend beyond the edges of the platform.

Use of PHS pedestals is optional. Exhibitor may use **one or two** PHS pedestals— choice of three sizes (12" x 12" x 12", 12" x 12" x 24", 12" x 12" x 32"). If you opt to use PHS pedestals, please notify the Class Advisor with the number and size of the pedestals you are requesting. Quantities are limited, so they will be allocated on a first come, first serve basis.

The staging will be painted "Olympus White" (Sherwin-Williams 6253).

Not to scale

PLATFORM

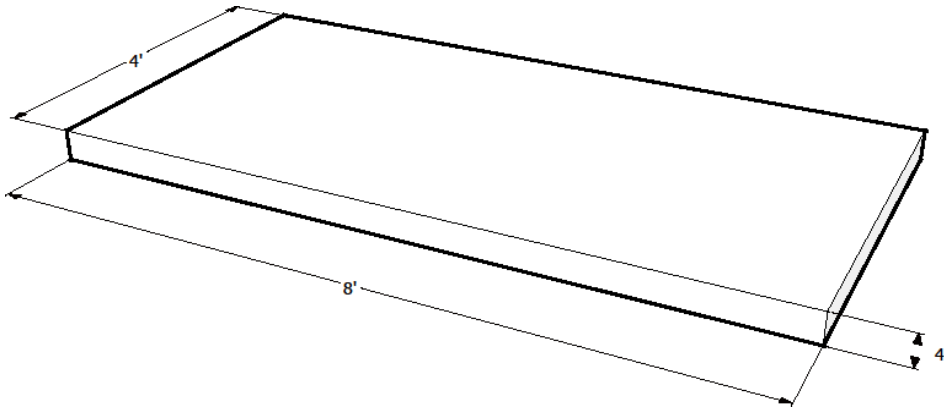

PEDESTALS

12" x 12" x 24"

12" x 12" x 32"

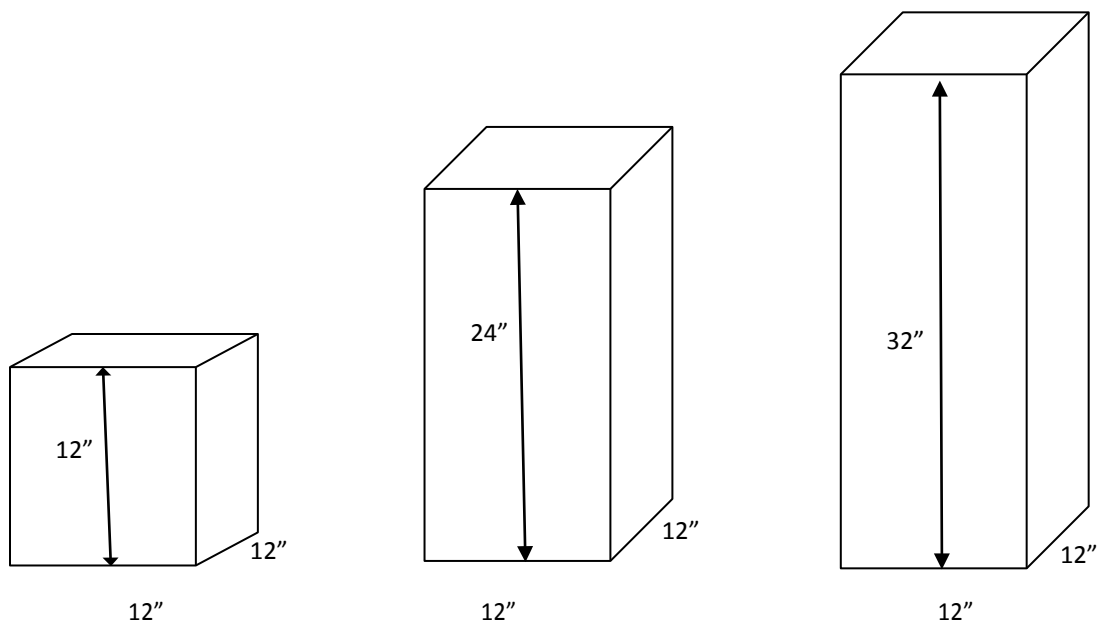

DRESS FORMS (Class 103-P)

Dress forms will be staged on a platform 8' wide by 4' deep by 4" high. No part of the entry may extend beyond the sides of the platform.

The dress form **may not** be elevated in any way and must stand on the platform itself. No rug, mat or other materials may be placed beneath the dress form. No accessories of any kind may be placed on the platform.

You may not glue or otherwise permanently adhere materials to the dress forms. You may not paint or otherwise alter the dress forms.

A pre-made dress may be used as a starting point but should be significantly altered so that the finished entry is made **primarily** of plant material. Necklaces, belts or other dress accessories are permitted if they are made **entirely** of plant material.

Not to scale



MEDIUM NICHES

101-M, 104-M, 109-M, 115-M

Please be sure to read the *General Rules and Information* (Page 10) and *Staging Information – Medium Niches* (Page 11) in the Exhibitor’s Guide.

Not to scale

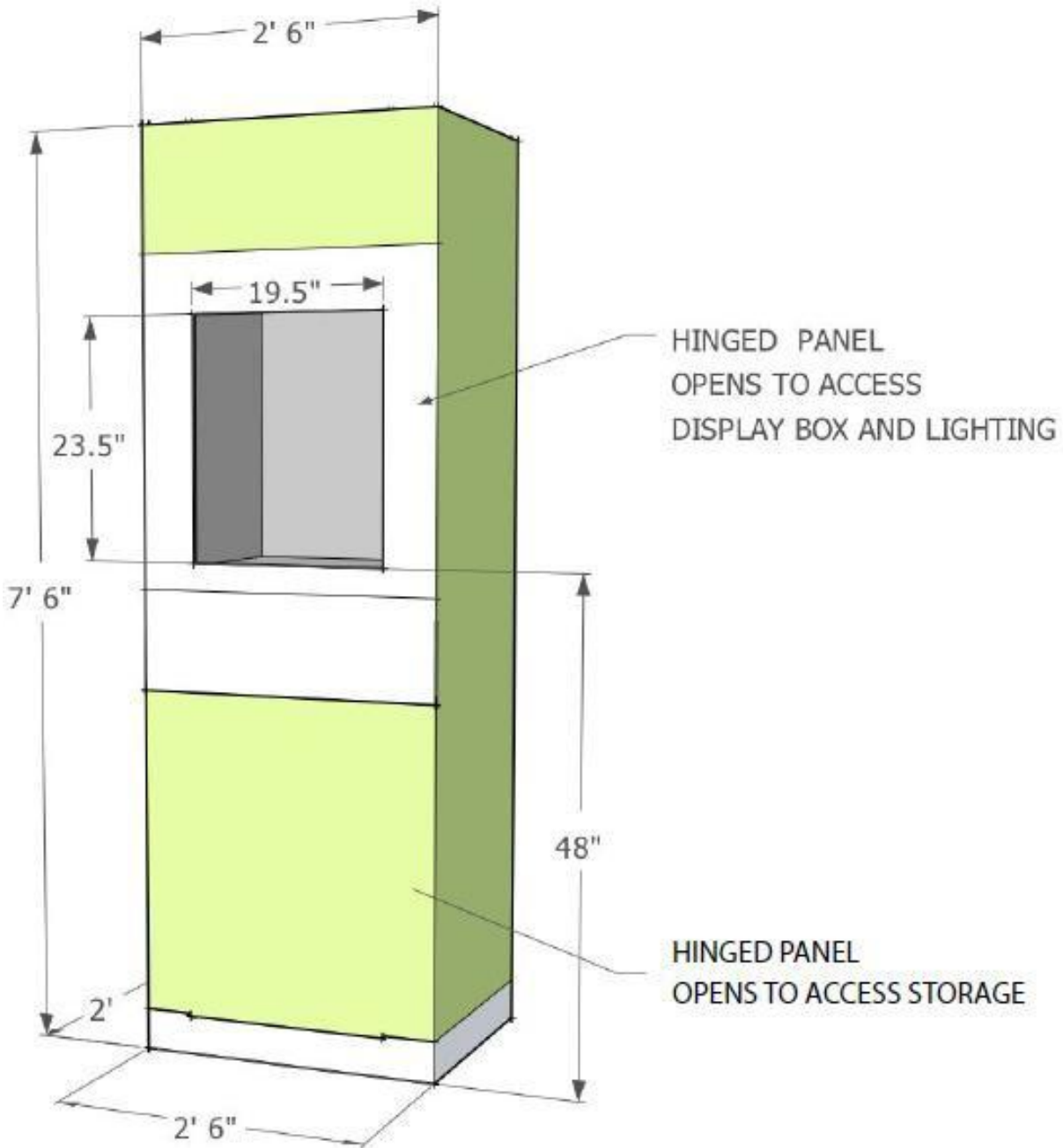

MEDIUM NICHE DISPLAY BOX
20"w x 16"d x 40"h interior dimensions

LINING MEDIUM NICHE WITH MAT BOARD

These dimensions are suggestions. Please test your linings in the niches that will be available at the PHS Artistic Workshops or in your own practice niche. **Note: Niche boxes vary in precise measurements. During Show set-up, a technical team is available for making minor adjustments to mat boards.**

MEDIUM NICHE

Interior Measurements

- Floor: 20" wide x 16" deep
- Back: 40" high x 20" wide
- Sides: 34" high x 16" deep

Lighting Placement (note that the light bar is not moveable)

1. Height from floor of niche to bottom of light bulb: 30½"
2. Edge of light bulb to back of niche: 6"
3. Edge of light bulb to front: 7"

Guidelines for cutting a background mat for Medium Niche

1. Brace at top front is 1½" in height
2. Measurement from bottom of niche to light bar: 35"

Guidelines for framing the opening (optional)

Cut outside dimensions of the frame 22" wide and 30" high. This will allow 3" above the cut-out niche opening and 3" below for attaching to the inside of the door and an inch on each side.

Closing Mechanism

Catch mechanism for closing the niche is 3" below the bottom of the cut-out opening in the door.

Option 1—Straight Background

It is not a requirement for the mat board to extend 40" high. Recommended sizes are as follows: Cut mat board back 36" high x 19-15/16" wide; 2 sides 34" high x 15-15/16" deep; floor 19-15/16" wide x 15-15/16" deep. If using foam core, cardboard, or fabric, be sure to allow for the thickness of your material.

Option 2—Curved Background

To create a curved background in the Medium Niche, use a standard-size mat board 32" high x 40" wide plus a floor piece cut 19-15/16" wide x 15-15/16" deep. It is desirable to make the background at least 34" high by taping an additional 2" piece to the standard-sized board along the side that will be the top of the background. Tape the two pieces together on the back of the board. After inserting the board, tape this piece to the box with masking tape. Adding the additional piece will carry the color up into the niche should viewers be able to look up into the niche box.

Insert the floor piece into the niche first. Then insert the mat board into the niche by holding the sides and bringing the sides together slightly to create a gentle curve in the center of the mat board. Gently insert the board up and toward the back of the niche. Slowly release the sides after the bottom of the board is inside and towards the back of the box.

SMALL NICHE

102-S, 105-S, 110-S, 116-S

Not to scale

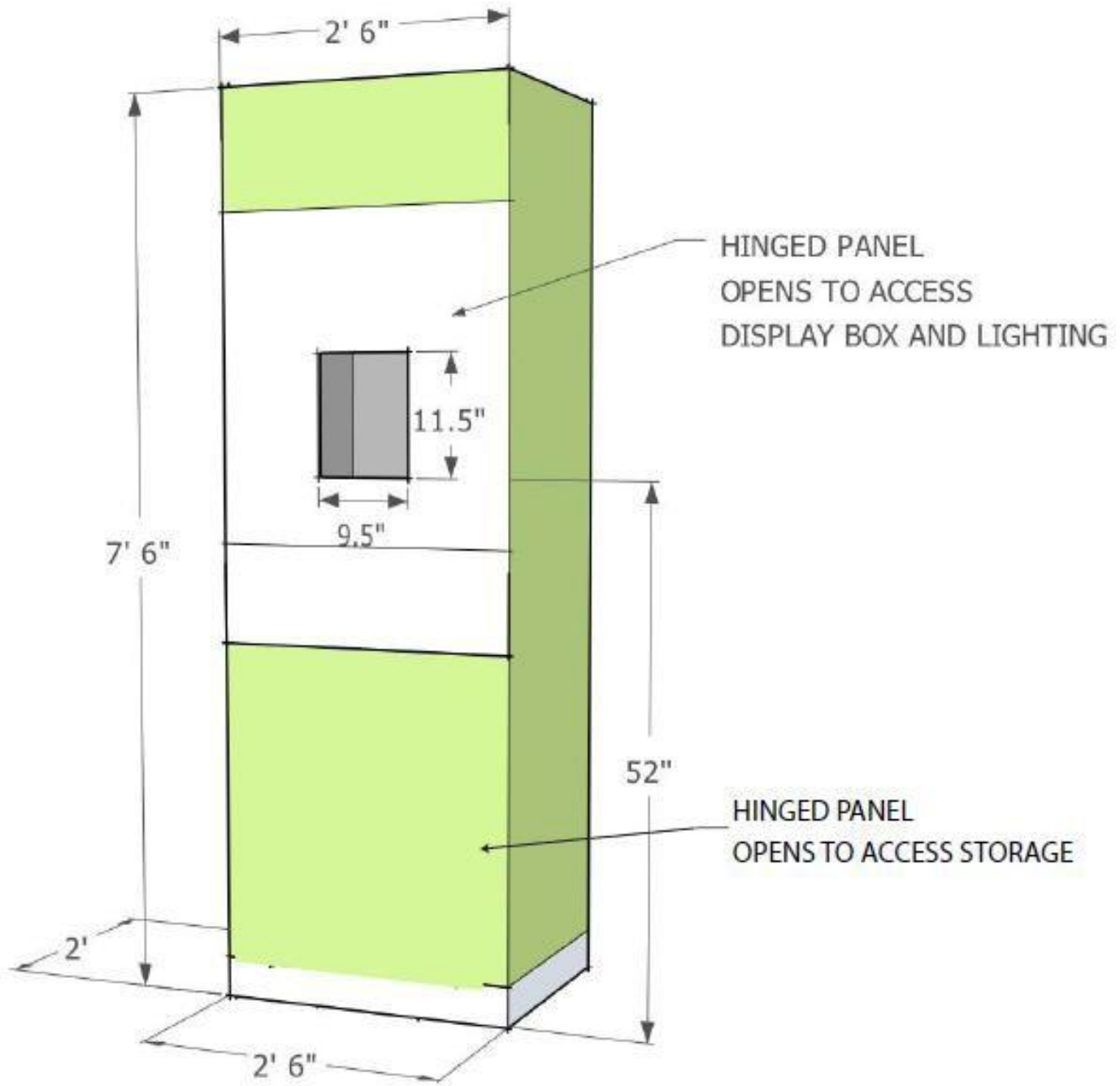

SMALL NICHE DISPLAY BOX
10"w x 8"d x 28"h interior dimensions

SMALL NICHE Guidelines

Please be sure to read the *General Rules and Information* (Page 10) and *Staging Information – Small Niches* (Page 11) in the *Exhibitor's Guide*.

Lining a Small Niche with Mat Board

These dimensions are suggestions. It is recommended that you test your linings in the niches that will be available at the PHS Artistic Workshops in January or in your own practice niche. Please note that individual niche boxes vary in their precise measurements. During Show set-up, a technical team is available for making **minor** adjustments to your pre-cut mat boards.

INTERIOR MEASUREMENTS

- Floor: 10" wide x 8" deep
- Back: 28" high x 10" wide
- Sides: 28" high x 6" deep

MAT BOARD MEASUREMENTS

A straight or curved background may be used.

Mat Board – Straight Background

Cut back 25" high x 9 15/16" wide; 2 sides 25" high x 7 15/16" deep; floor 9 15/16" wide x 7 15/16" deep. If using foam core, cardboard or fabric, be sure to allow for the thickness of the material.

Note: Niche boxes vary in precise measurements. During Show set-up, a technical team is available for making minor adjustments to mat boards.

LIGHTING

Small niches are supplied with one light bulb. Lights are dimmable and swivel, although the light bar is fixed. Exhibitors may exchange the PHS bulb for a bulb color of their choice depending on the desired mood, but the bulb **MUST BE AN LED BULB NOT TO EXCEED 75 WATTS**. Replaced PHS bulbs must be stored safely in the niche storage area for the next exhibitor.

OTHER INFORMATION

Small Niche Locks

A magnet mechanism locks the niches and requires a special key to release the magnets. Your Advisors will have the keys to open and close the niches during set-up and maintenance times.

Niche Storage

There is a small area in the bottom of each niche for storing extra flowers and tools, as well as the PHS light bulbs, if you decide to change them out. Please remember that access to this storage requires the niche to be opened by an Advisor with the special magnetic key.

GALLERIA

125-G, 126-G, 127-G, 128-G

Not to scale

Each exhibit space is a platform 8' wide, 8' deep, 4" high. The back wall of the area is 10' high. Optional pedestals—choice of two sizes (12" x 12" x 12", 12" x 12" x 24"). The staging will be painted "Olympus White" (Sherwin-Williams 6253).

For those entering 126-G and 127-G, posters will be available for pick-up from the PHS office or can be mailed to exhibitor from PHS after your entry is confirmed. Please email jcelius@pennhort.org to arrange to have your poster mailed. PHS will mount a duplicate poster for display. Please note: Poster will be displayed on the left, with the arrangement to the right.

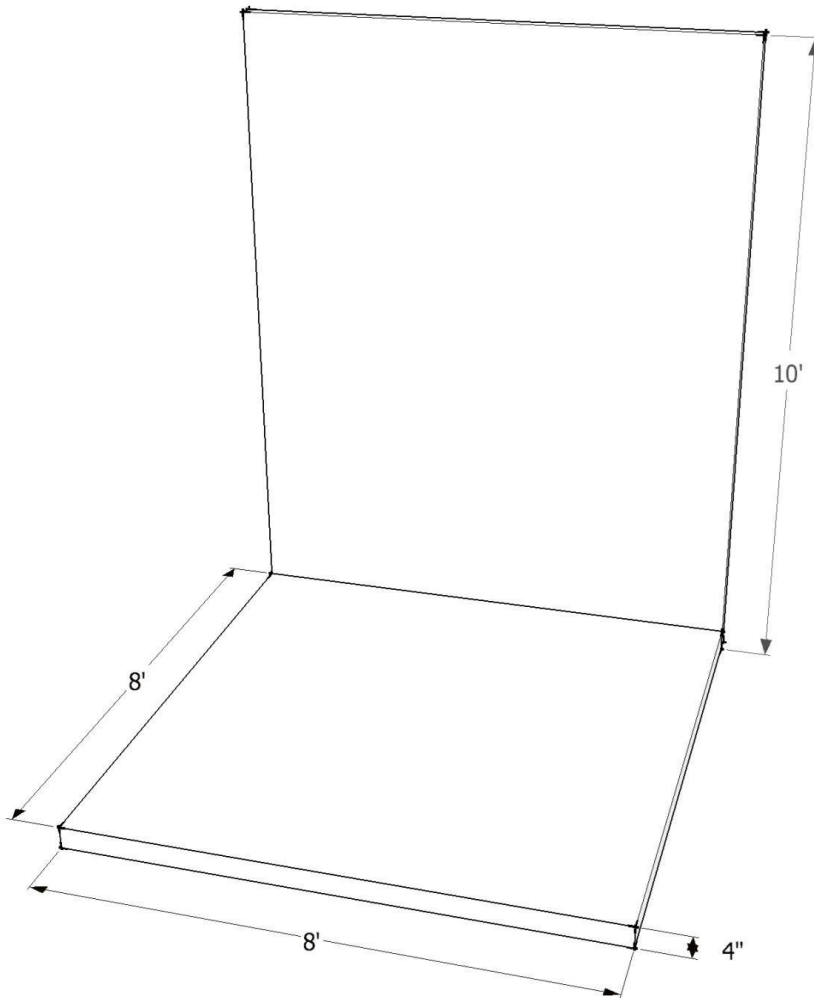

BACKED PEDESTAL

129-BP, 130-BP, 131-BP, 132 BP

Please be sure to read the *General Rules and Information* (Page 10) and the *Staging Information* (Page 12) in the Exhibitors Guide.

Staged on a platform 8' wide, 4' deep, 4" high. Pedestals are 36" wide x 24" deep x 36" high; height of back is 36" (total height of unit on platform is 72").

NEW: Backgrounds are NOT permitted in any Backed Pedestal Class.

The staging will be painted "Olympus White" (Sherwin-Williams 6253).

Not to scale

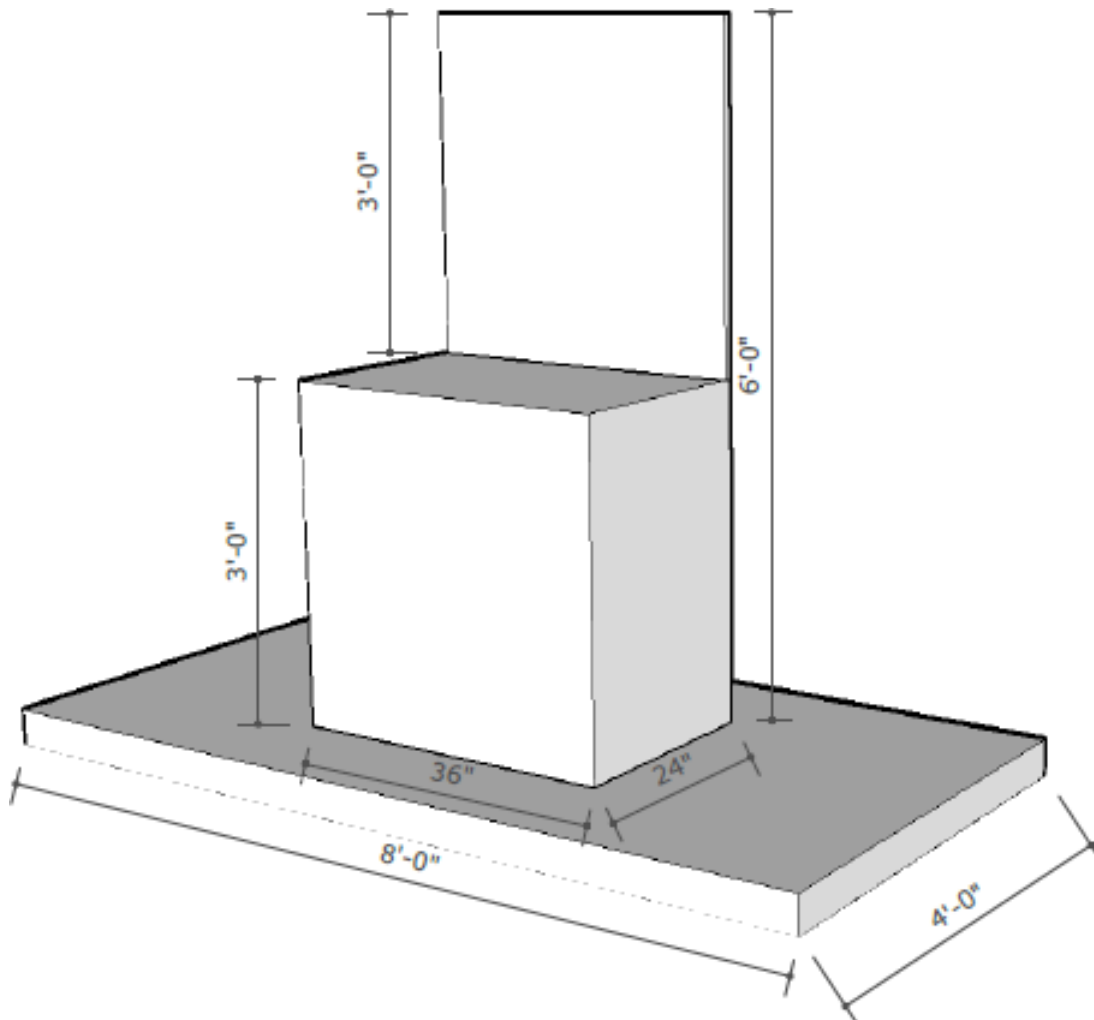

36"W X 24" D X 36" H pedestal with
36" W x 36" H back board.

ADDITIONAL CLASS INFORMATION

Head Forms

- Head forms can be picked up in January with prior arrangement from PHS. If head forms must be shipped to the exhibitor, exhibitor must pay shipping charges. Please email Jenna Celius at jcelius@pennhort.org with your pick-up plans.
- You may not glue or otherwise permanently adhere materials to the head forms. You may not paint or otherwise alter the head forms, as the head forms are reused.
- Hats may be composed of a combination of dried and fresh plant material, but some fresh plant material **MUST** be used. How much fresh plant material to use is up to the exhibitor.
- Dried plant material may be painted. Fresh plant material may **NOT** be painted or colored in any way.
- Plant material intended to fulfill the class requirement for “fresh” must be fresh when the exhibit is entered. If fresh plant material is used without a water source, it is necessary to do one of two things: 1) Plants must be tested to see if they will remain fresh for the time they are to be displayed and approved by one of the Passing Chairs at least one week prior to the Show; 2) Plants **MUST** be replaced with fresh material each morning before the Show opens.
- The basic hat structure may be created entirely from “scratch” or it may be creating using an existing form. Whichever approach is taken, the requirement to conceal the mechanics with plant material applies, unless an aspect of the mechanics is used as a design element. If a ready-made hat is used, it must be entirely concealed with plant material.
- Accessories are **NOT** permitted (for example, a necklace, scarf or earrings or any item that is not a part of the hat.)
- Hat design should be in proportion to the head, not the size of the backed pedestal.
- **NEW:** Backgrounds are **NOT** permitted in any Backed Pedestal Class. A mat, fabric or any other materials may **NOT** be placed beneath the head form.

Tabletop Frames

- Tabletop frames will be provided by PHS at the Show.
- You may not glue or otherwise permanently adhere materials to the frames. You may not paint or otherwise alter the frames, as the frames are reused.
- The design may include dry plant material, but fresh plant material **MUST** predominate.
- The frame must remain placed in the middle of the Backed Pedestal.
- The design should be in proportion to the overall size of the backed pedestal. Nothing may extend beyond the sides or front of the Backed Pedestal.
- **NEW:** Backgrounds are **NOT** permitted in any Backed Pedestal Class. A mat, fabric or any other materials may **NOT** be placed beneath the frame.

Not to scale.

Pot-et-fleur

- The design required is a “pot-et-fleur design” which combines fresh cut flowers and rooted plants assembled in ONE container.
- Two or more rooted plants **MUST** be included in the design.
- The arrangement may **NOT** extend beyond the top or sides of the Backed Pedestal. Plant material **MAY** extend over the front of the Backed Pedestal but may not touch the floor structure.
- The design should be in proportion to the overall size of the backed pedestal.
- **NEW:** Backgrounds are **NOT** permitted in any Backed Pedestal Class. A mat, fabric or any other materials **MAY** be placed beneath the pot-et-fleur design.

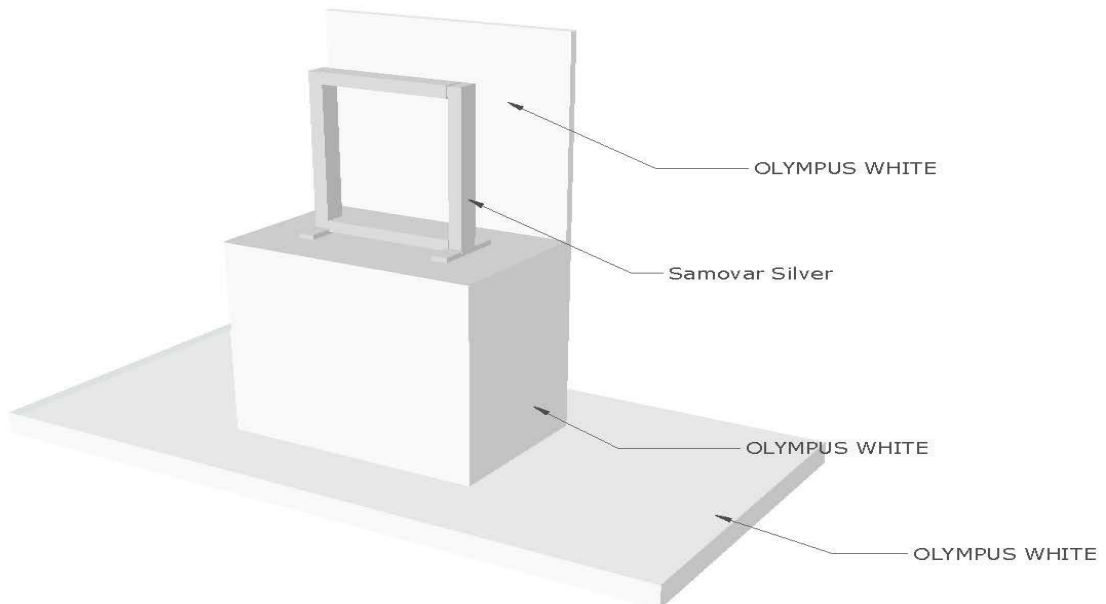
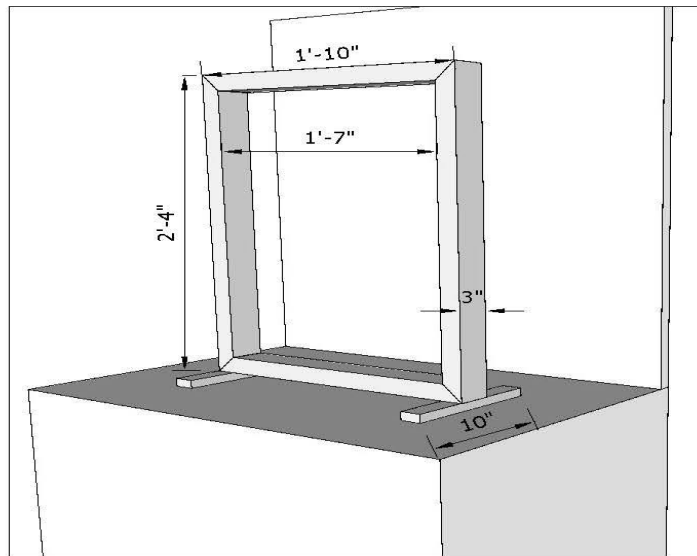

MINIATURE ARRANGEMENTS

119, 120, 121, 122, 123, 124

Not to scale

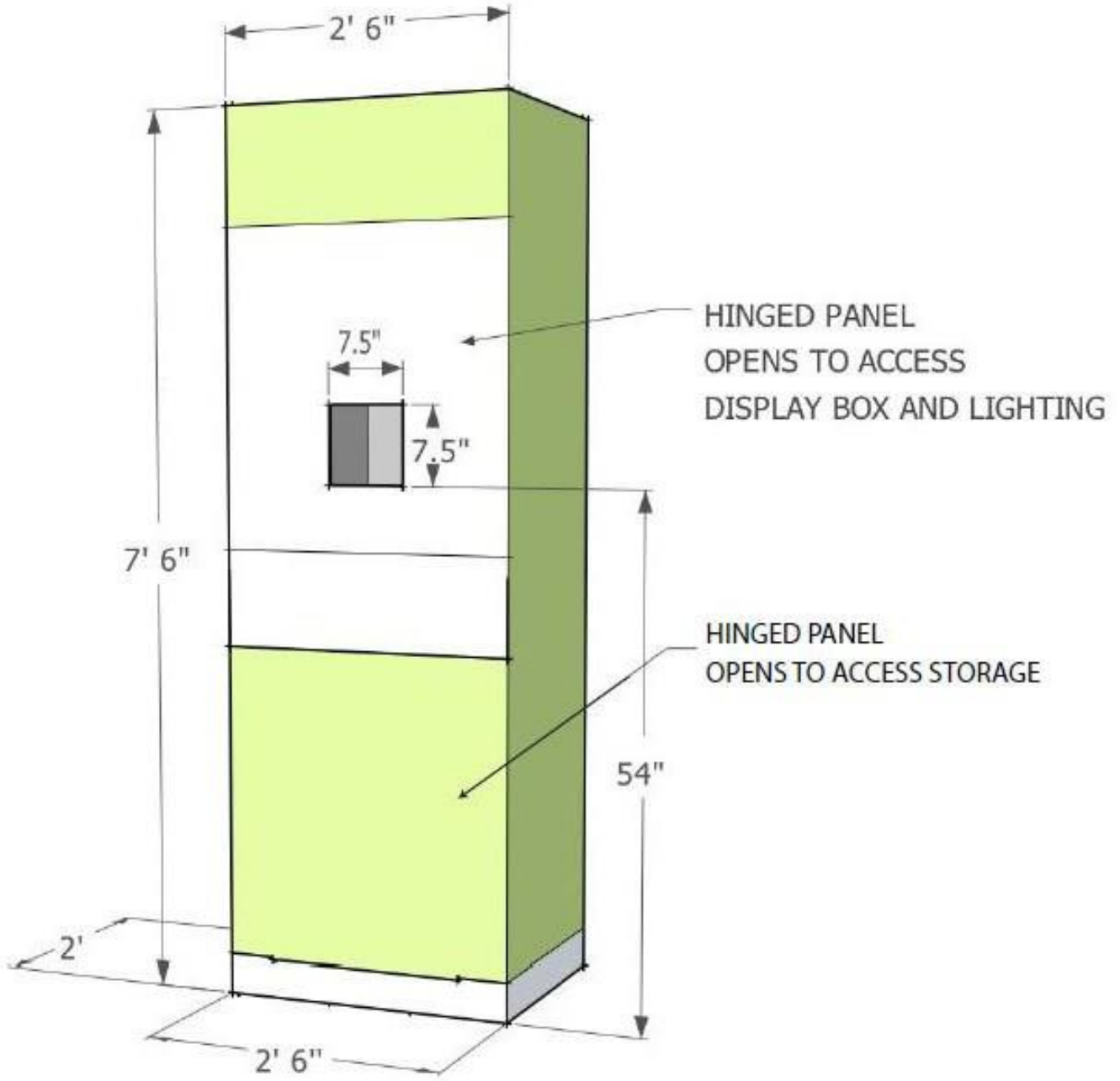

MINI NICHE DISPLAY BOX
8"w x 8"d x 16"h interior display box

MINIATURE ARRANGEMENT GUIDELINES

Please be sure to read the *General Rules and Information* (Page 10) and *Staging Information – Miniature Arrangements* (Page 12) in the Exhibitor's Guide.

INTERIOR MEASUREMENTS

- Bottom: 8" wide x 8" deep
- Back: 16" high x 8" wide
- Sides: 16" high x 8" deep.

Mat board is required, no poster board or other material is allowed for lining minis. No fabric or other material may be attached to the mat board.

MAT BOARD MEASUREMENTS

- Cut one back and two sides 7-15/16" wide x 12" high (minimum) to 15-1/2" high (maximum)
- Cut bottom 7-15/16" wide x 7-15/16" deep.

A curved mat board back may be used, if interior dimensions remain 8" wide by 8" deep.

Use of a frame, to mask the raw edges of the niche and frame your design, is permitted. PHS will have available 1" square black mat frames to borrow. Alternatively, you may provide a frame of your own shape and color. Total covering of the framed opening is not permitted Use of a frame is optional.

LIGHTING

Miniature arrangements come with one light fixture and bulb are provided. The light is fixed in place so it cannot be moved, but it can be dimmed. You **MUST** use the PHS light bulb provided.

OTHER INFORMATION

Fresh plant material **CANNOT** be used in a miniature arrangement.

Arrangements cannot exceed 5" in height, width or depth. To ensure your design does not exceed this requirement, make a 5" square out of cardboard and hold it up to your arrangement on all sides. If nothing shows in any direction, you are good to go.

Niche Boxes

PHS provide a niche boxes for each exhibitor on the show floor. Alternatively, exhibitors may build their own niche box so it can be drilled into it and pre-assembled. It is critical that constructed niche boxes are the exact size of those provided by PHS. See construction information that follows.

Niche Locks and Storage

A magnet mechanism locks the niches and requires a special key to release the magnets. Your Advisors will have a key to open and close the niches during set-up and maintenance times.

There is a small area in the bottom of each niche for storing extra flowers and tools, as well as PHS niches that are not used. Please remember that access to the storage required the niche to be opened by an Advisor with the special magnetic key.

MINIATURE ARRANGEMENT BOX CONSTRUCTION TIPS

Materials

- 1/2" plywood sheet measures 2' x 4'
- Wood Glue

Need to Cut

- One back: 8" x 15 1/2"
- Two sides – each: 8 1/2" x 15 1/2"
- One Floor: 8" x 8"

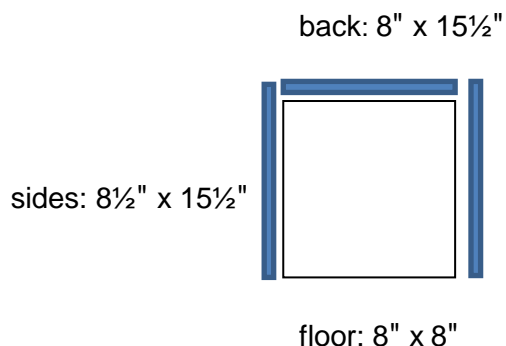

Not to scale

To finish: Position back and sides around the floor. Glue back and sides together, gluing sides alongside the back, so that the floor space is 8" x 8".

Put glue on 3 sides of the floor and slide it into the back and sides pieces.

Write your name on the back of the box.

Assembled (not to scale)

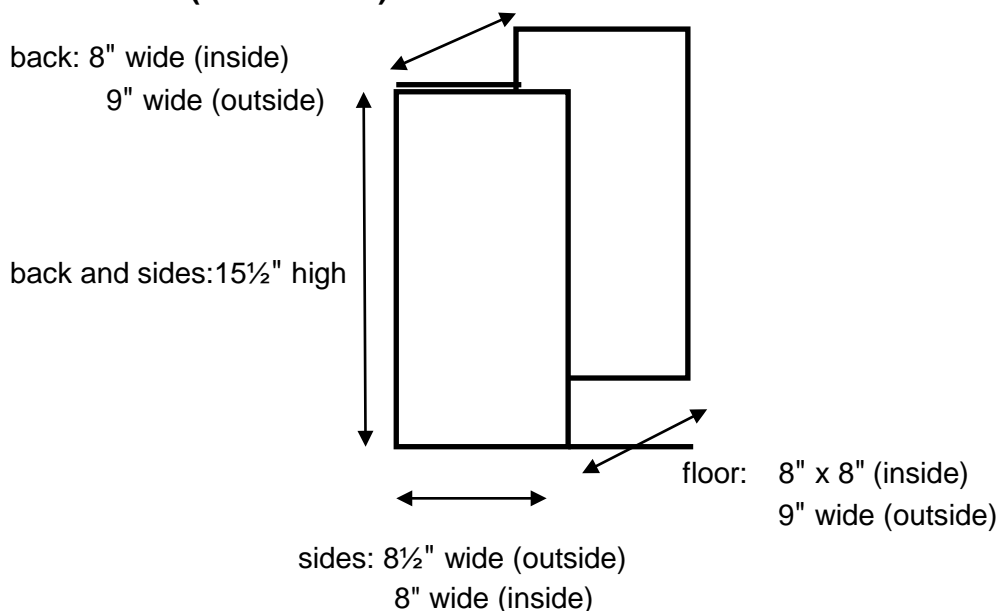

PHOTOGRAPHS OF NICHE BOX LIGHTING



MEDIUM



SMALL

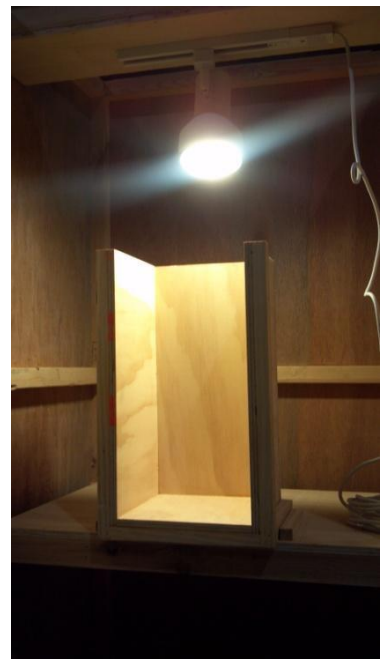

MINI

FRAMES

